

Normalizing The Time-Domain Response of Oscilloscope Probes

by Mike McTigue, Agilent Technologies

High-performance oscilloscopes are typically used to measure the time-domain characteristics of fast digital signals, such as rise and fall times, settling time, overshoot or undershoot, eye opening, and jitter. The time-domain response characteristics of oscilloscopes and probes are an important figure of merit.

Traditionally the two important “banner specs” on an oscilloscope data sheet have been bandwidth and risetime because they are both important indicators of how faithfully the oscilloscope and probe system reproduce the signal present at the probe tip; but caution must be used in interpreting these specifications.

An oscilloscope probe is a “voltage in-voltage out” device, so its transfer function produces an output voltage for a given an input voltage. Bandwidth is defined as the point where the transfer function, expressed in the frequency domain, is 3 dB down. The probe will faithfully reproduce the input signal if it has sufficient bandwidth and its passband is flat.

Risetime is defined as the time from a low point to a high point (usually 10% - 90% or 20% - 80%) on the step response of the transfer function expressed in the time domain. The probe will faithfully reproduce the input signal if the risetime is low enough and the top of the step settles quickly after the edge.

When a probe is connected to a point with finite source impedance, it will necessarily alter the voltage seen at that point. With a proper test setup, both the input and output signals can be measured in either the frequency or time domain. The frequency domain transfer function is easily determined by dividing the measured output by the measured input. However, determining the step response of a probe is more difficult because instead of division to determine the transfer function, convolution is required. An equivalent method to determine the step response is to force a perfect step on the input of the probe and then the step response can be directly viewed on the output.

There is a good method available to characterize the step response of oscilloscope probes using normalized time-domain transmission (TDT) measurements providing a way to effectively force a perfect step on the input of a probe so the step response can be measured. Many high-bandwidth sampling oscilloscopes provide software for normalized measurements. The normalization process takes the waveform at the input of the probe and constructs a filter which, when applied to the input of the probe, produces a “perfect” step, and when applied to the output of the probe, correctly derives the probe’s response to a perfectly flat input step. Ref 1 gives more background on the normalization process.

The example we will use in this article is an Agilent 1134A 7 GHz InfiniiMax probe with a solder-in probe head. The test equipment used is:

- A sampling oscilloscope (an Agilent 54750A or any high-bandwidth sampling oscilloscope with TDR and normalization)
- A probe deskew/performance verification fixture (Agilent E2655A)
- A probe power supply (Agilent 1143A)
- An auto-probe interface adaptor (Agilent N1022A)
- An outside thread 3.5-mm adaptor (Agilent 5062-1247)
- A short high-quality 3.5-mm or sma coax cable
- A 50- Ω termination (Agilent 909D)
- A differential solder-in probe head (Agilent E2677A)

The test equipment setup (Fig. 1) is:

- Connect the probe deskew/performance verification fixture to a sampling oscilloscope channel input using high-quality adapters
- Connect a TDR channel to the other side of the verification fixture using a short high-quality cable

- Connect the probe power supply, auto probe interface adaptor, and outside thread adaptor to the oscilloscope probe to be tested

Setup the sampling oscilloscope so the TDR step is “on” on the proper channel and the measuring channel is being viewed. The block diagram for the equipment setup is shown in Fig. 1. The waveform seen when this setup is done properly should be very similar to the waveform in Fig. 3.

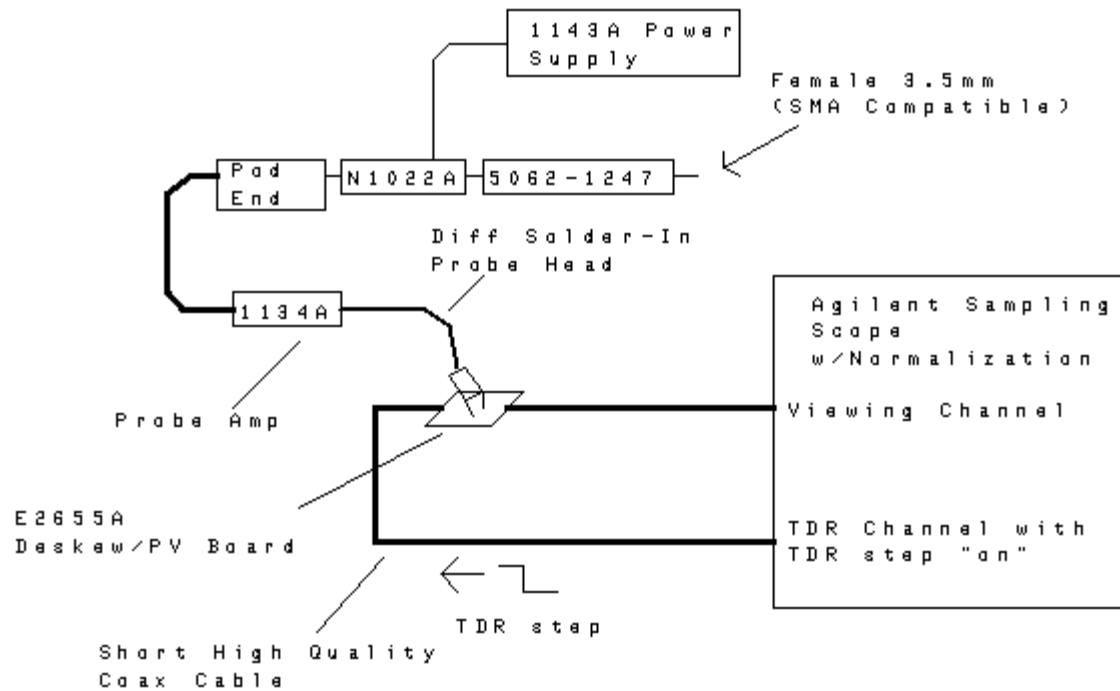

Setup for Measuring Input Step

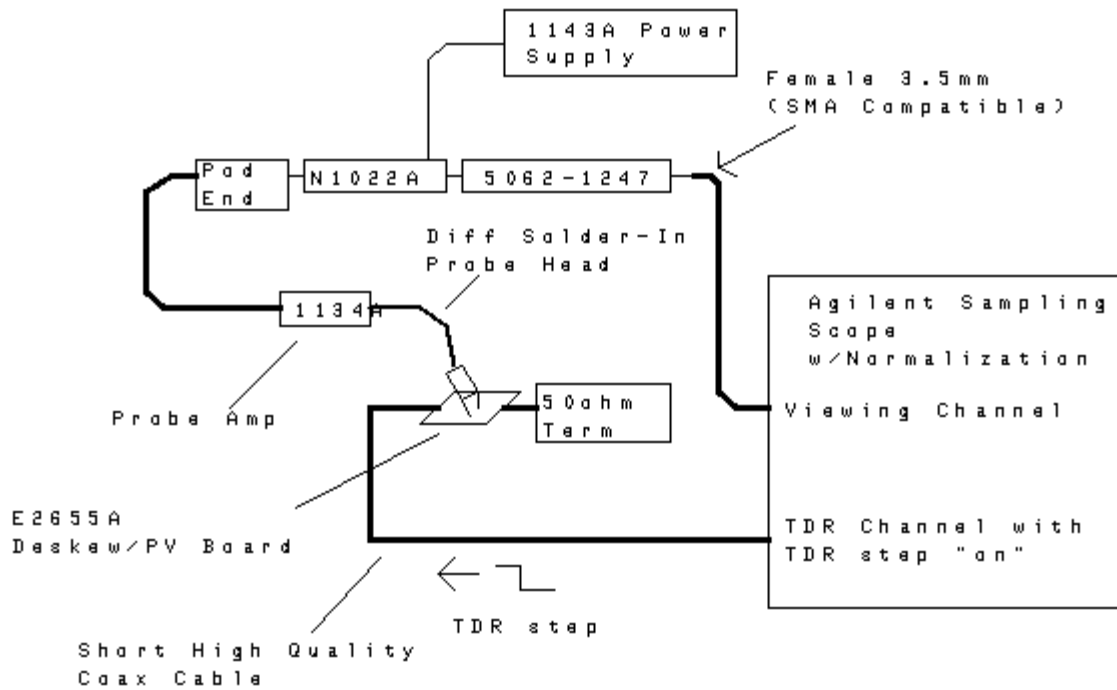

Setup for Measuring Probe Output Step

Fig. 1: Equipment Set Up For Measuring Input and Output of Probe

The probe deskew/performance verification fixture allows us to connect the probe tip to a 50-Ω transmission line (Fig. 2).



Fig. 2: Probe Deskew Fixture Allows Easy Connection of Probe Tip To 50-Ω Transmission Line

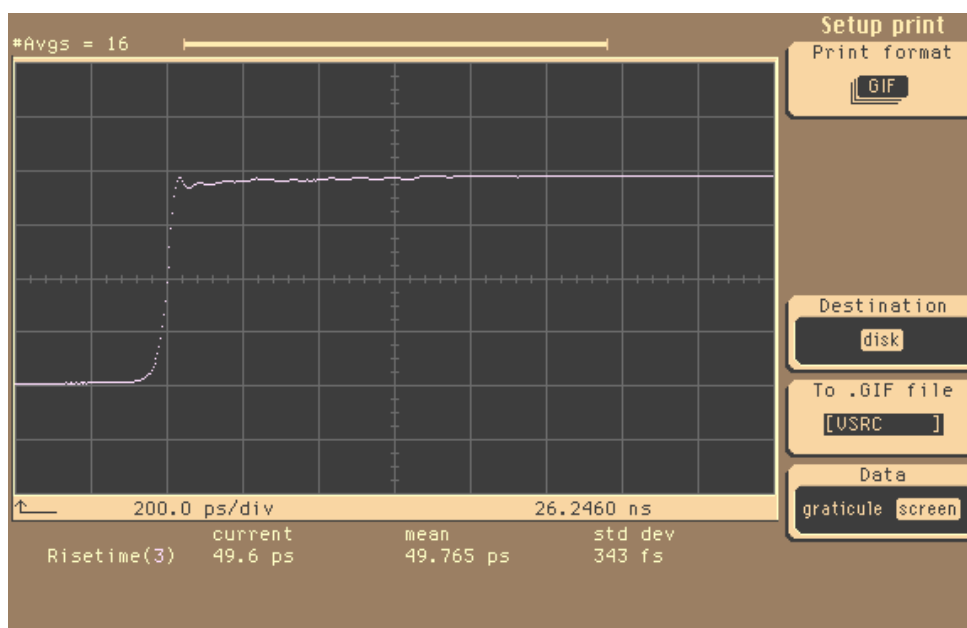

Fig. 3: TDR Step Response

Fig. 3 shows the TDR step from channel 4 as viewed on channel 3 through the test setup. Notice that it is somewhat slowed down from the nominal 35-ps 10 - 90% step of the TDR step generator. This is due to the loss through the test setup.

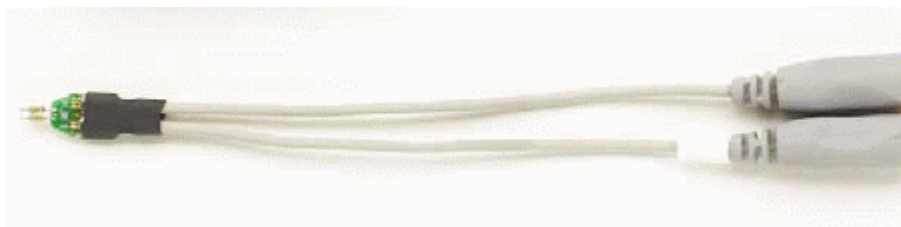

Fig. 4: Differential Solder-In Probe Head

Connect the differential solder-in probe head (Fig. 4) to both the probe amplifier and the probe deskew/performance verification fixture. Align the positive side to the center conductor on the

verification fixture and the negative side to either ground conductor under the retainer clip. Release the clip and lift slightly to make sure good contact is made. Now the probe input impedance is loading the through line on the verification fixture so we should see the loading effects on this edge (Fig. 5).

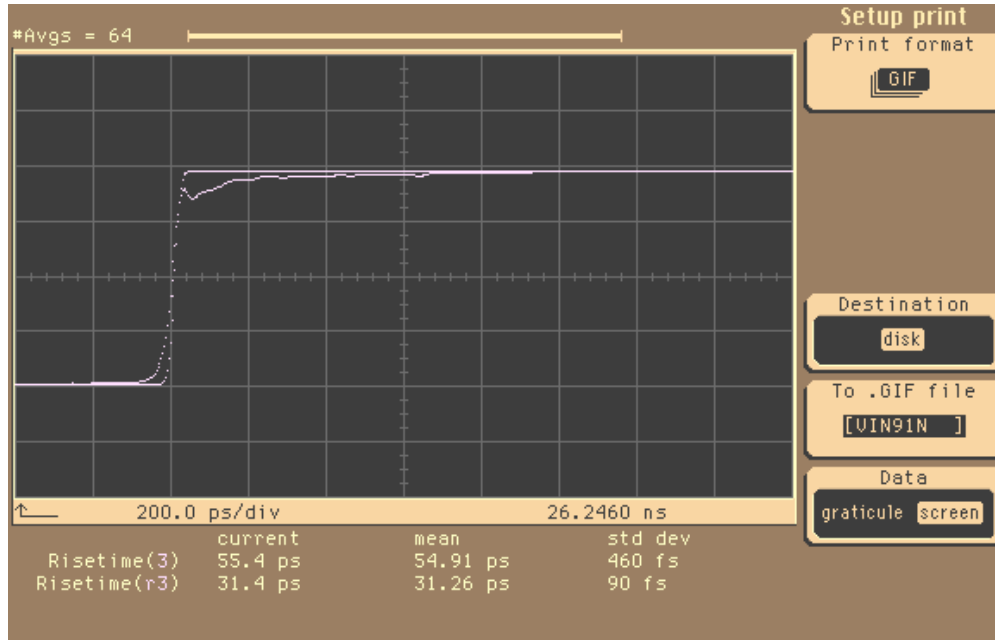

Fig. 5: Differential Solder-In Probe Head Connected To Probe Fixture

With the probe loading the line we will perform a time-domain transmission (TDT) normalization in the sampling oscilloscope (Ref 1). This normalization takes the step that is applied to the input of the probe and propagates forward on the transmission line into channel 3, and constructs a digital filter that when applied to the input step produces a “perfect” 31-ps step. This step (Fig. 5) is response 3 or “r3.” Note that its 10 - 90% rise time is 31.26 ps. Now we have a filter that can correct the actual input step to a fast, flat input step and if we apply this filter to the output of the probe we will be able to view the step response of the probe to this 31-ps step. To view the output, we disconnect the verification fixture from the sampling channel and terminate it with 50-Ω, then connect the output of the probe to the sampling channel (Fig. 6).

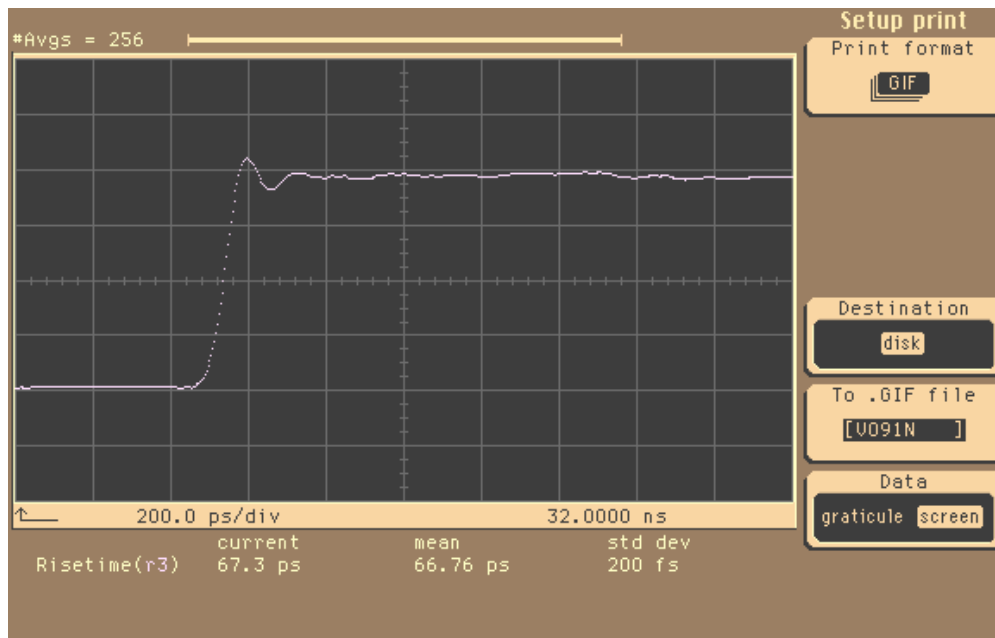

Fig. 6: Probe Des skew/Performance Verification Fixture Response As Measured

Since the input and output steps do not have excessive overshoot, we can use the square root of the sum of the squares to approximate the rise time of the probe only. The result is:

$$tr_{\text{probe only}} \approx \sqrt{(66.67 \text{ ps}^2 - 31 \text{ ps}^2)} = 59 \text{ ps (10-90\%)}$$

In summary, measuring the bandwidth and flatness of a high-bandwidth voltage probe is relatively straightforward and the methods are traceable to NIST (National Institute of Standards and Technology) standards. However, measuring the true step response of a high-bandwidth voltage probe is not as easy as just connecting the probe to a fast step and looking at the output of the probe. This is due to both the imperfections in the step source and the loading effects of the probe.

Conclusions

In order for the output of the probe to represent the step response of the probe, the input must be driven with an ideal step, which is difficult if not impossible to achieve in practice. A much more accurate method is to use normalization techniques to correct the input and, then, output waveforms. A fast, flat step response ensures that the waveform viewed on screen is faithful to the waveform at the probe tip, but the step response must be correctly measured to have any meaning. The step response is not really traceable to NIST standards because of the inherent difficulties in dealing with time-domain issues, but normalization techniques are a way to achieve very high confidence in step-response measurements in lieu of traceable standards.

About The Author

Michael T McTigue received his BSEE from Arizona State University in 1979. He began working for Agilent Technologies (then Hewlett-Packard) in 1979 in thick-film hybrid development in the Colorado Springs Technology Center. In 1983, he moved into the oscilloscope R&D lab to work on design and development of next-generation oscilloscopes and probes. Mike has been involved with the development of the company's sampling oscilloscope products and Mega-Zoom realtime oscilloscopes. Recently, he was instrumental in the definition and implementation of the probing systems needed for next-generation high-bandwidth oscilloscopes, including the award-winning 7-GHz differential and/or single-ended probe system. He is an avid skier and golfer, enjoys camping and boating with his family, and occasionally finds time for his guitar.

Reference:

"Improving TDR/TDT Measurements Using Normalization," Agilent application note 1304-5, Agilent publication number 5988-2490EN.

