

**"Innovation,
not imitation"**

CA SERIES

PRECISION REGULATED, LOW RIPPLE HIGH VOLTAGE DC TO DC CONVERTERS

0 to +/-200V through 0 to +/-2000VDC @ 1 Watt



PRODUCT DESCRIPTION

Precision regulated, very low noise, high performance high voltage power supplies are fully programmable (0 to 100%) and feature high voltage monitor readback, on-board precision reference, wide input voltage range and protection against arcs and short circuits all in a miniature, shielded case.

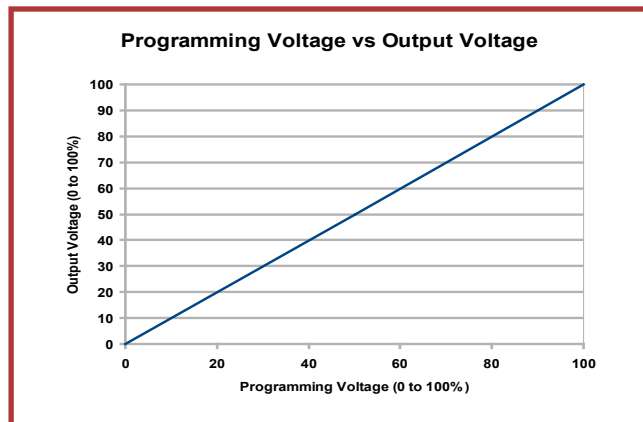

APPLICATIONS

Photomultiplier Tubes
Avalanche Photodiodes
Solid State Detectors
Electrophoresis
EO Lenses
Piezo Devices
Capacitor Charging

PRODUCT SELECTION TABLE

MODEL	OUTPUT VOLTAGE (POSITIVE OR NEGATIVE)	MAXIMUM OUTPUT CURRENT ^{*1}
CA02	0 to 200V	0 to 5 mA
CA05	0 to 500V	0 to 2 mA
CA10	0 to 1,000V	0 to 1mA
CA12	0 to 1,250V	0 to 0.8 mA
CA20	0 to 2,000V	0 to 0.5 mA

Complete List of Models on page 2

FEATURES

- Very Low Ripple, as low as 5PPM!
- Precision Regulated
- Miniature Shielded Case, 1 cubic inch
- 0 to 100% Programmable output
- Voltage Monitor/ Readback
- High Stability, typically <25ppm/°C
- Wide Input Voltage Range
- Arc, Short Circuit Protected
- 12 Vin; indefinite
- 5 Vin; short duration, up to 1 minute
- Very Low EMI/RFI
- Precision On board Reference
- External Voltage or Potentiometer Programming
- Accessible Calibration Adjustment
- Sealed To Withstand Immersion Cleaning Processes
- Designed to meet the requirements of UL1950
- Proven Reliability, MTBF: >2.10 million hrs per Bellcore TR-332
- UL94-V0 Compliant Epoxy

OPTIONS

- Available in two Standard Input Voltage Ranges: 5 and 12 VDC
- Extended Operating Temperature: -55°C to +70°C
- Storage Temperature of Extended Temperature option: -55°C to +95°C
- Low Out-gassing Epoxy (NASA approved per ASTM E-595-93)
- RoHS versions available (R suffix)

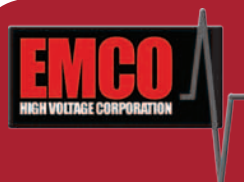

www.emcohighvoltage.com
e-mail: sales@emcohighvoltage.com
phone: (209) 267-1630, fax (209) 267-0282
70 Forest Products Rd., Sutter Creek, CA 95685 USA

ELECTRICAL SPECIFICATIONS*2 CA02 - CA20 (200V to 2000V)

OUTPUT VOLTAGE	MODEL	MAXIMUM OUTPUT CURRENT*1	RIPPLE P-P FULL-LOAD*3	REGULATION		FREQUENCY*3
				LOAD 0 TO 100%*3	LINE 11.5 TO 16.0V*3	
12 VDC INPUT MODELS						
0 to +200V	CA02P	0 to 5 mA	<0.01 %	<0.05 %	<0.01 %	80 - 180 kHz
0 to -200V	CA02N	0 to 5 mA	<0.01 %	<0.05%	<0.01%	80 - 230 kHz
0 to +500V	CA05P	0 to 2 mA	<0.01 %	<0.01 %	<0.01%	200 - 400 kHz
0 to -500V	CA05N	0 to 2 mA	<0.01 %	<0.01 %	<0.01 %	100 - 250 kHz
0 to +1,000V	CA10P	0 to 1 mA	<0.001 %	<0.005 %	<0.001 %	80 - 250 kHz
0 to -1,000V	CA10N	0 to 1mA	<0.001 %	<0.005 %	<0.001 %	100 - 250 kHz
0 to +1,250V	CA12P	0 to 0.8 mA	<0.0005 %	<0.005 %	<0.001 %	80 - 250 kHz
0 to -1,250V	CA12N	0 to 0.8 mA	<0.0005 %	<0.005 %	<0.001 %	80 - 250 kHz
0 to +2,000V	CA20P	0 to 0.5 mA	<0.001 %	<0.01 %	<0.01 %	80 - 250 kHz
0 to -2,000V	CA20N	0 to 0.5 mA	<0.001 %	<0.01 %	<0.01 %	100 - 250 kHz
5 VDC INPUT MODELS						
0 to +200V	CA02P-5	0 to 5 mA	<0.01 %	<0.01 %	<0.01 %	100 - 250 kHz
0 to -200V	CA02N-5	0 to 5 mA	<0.01 %	<0.005 %	<0.003 %	100 - 250 kHz
0 to +500V	CA05P-5	0 to 2 mA	<0.005 %	<0.003 %	<0.002 %	100 - 250 kHz
0 to -500V	CA05N-5	0 to 2 mA	<0.005 %	<0.005 %	<0.002 %	87 - 350 kHz
0 to +1,000V	CA10P-5	0 to 1 mA	<0.001 %	<0.005 %	<0.001 %	100 - 250 kHz
0 to -1,000V	CA10N-5	0 to 1 mA	<0.001 %	<0.005 %	<0.001 %	100 - 250 kHz
0 to +1,250V	CA12P-5	0 to 0.8 mA	<0.001 %	<0.005 %	<0.001 %	150 - 300 kHz
0 to -1,250V	CA12N-5	0 to 0.8 mA	<0.001 %	<0.005 %	<0.001 %	150 - 300 kHz
0 to +2,000V	CA20P-5	0 to 0.5 mA	<0.001 %	<0.005 %	<0.003 %	45 - 250 kHz
0 to -2,000V	CA20N-5	0 to 0.5 mA	<0.001 %	<0.001 %	<0.001 %	100 - 250 kHz

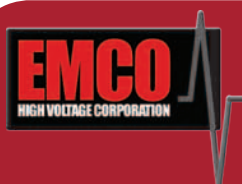

ELECTRICAL SPECIFICATIONS*2 CA02 - CA20 (200V to 2000V)

PARAMETER	VALUE
INPUT VOLTAGE	12V Input Models: +11.5 to +15.5V
	5V Input models: +4.75 to +5.25V
STANDBY POWER	<25mW*3
INPUT CAPACITANCE	440uF
PROGRAMMING VOLTAGE	12V Input Models: 0 to +5V, <150uA
	5V Input Models: 0 to +2.048V <150uA
SET POINT ACCURACY	1%
GAIN ADJUST	1%
LINEARITY	<0.5% (15% to 100% Vout)
STABILITY	<0.005%/hr*3
VOLTAGE MONITOR*5	12V Input Models: 0 to +5V = 0 to 100% Vout
	5V Input Models: 0 to +2.048V = 0 to 100% Vout
REFERENCE OUTPUT	12V Input Models: +5V +/- 1% , up to 1 mA
	5V Input Models: +2.048V +/- 1% , up to 1 mA
TEMPCO	<25ppm/°C*3
THERMAL SHOCK LIMIT	1°C/10 Sec.
OPERATING TEMP.	-10° to +50°C (Case)
OPTIONAL EXTENDED OPERATING	-55 to +70°C (Case)
STORAGE TEMPERATURE OF EXTENDED TEMPERATURE OPTION:	-55° to +95°C

	INPUT CURRENT			
	CA02-CA12		CA20x-5	
VIN	NO-LOAD	FULL-LOAD	NO-LOAD	FULL-LOAD
5 VDC	< 65mA	<420mA	<155 mA	<550 mA
12 VDC	<80 mA	<220 mA	<80 mA	<220 mA

DETAILED PRODUCT DESCRIPTION

The CA Series of high performance, precision regulated, high voltage power supplies offers improved performance and added features. Improvements in stability and ripple, along with an on board precision reference, a voltage monitor and increased protection, enable these modules to replace much larger, more expensive power supplies in many applications. Each model is programmed from 0 to 100% of rated output via a DAC compatible high impedance programming input. A voltage monitor is provided and is internally buffered to provide a low impedance (up to 1 mA) signal to external circuitry. The precision, on board reference can be used in conjunction with an external potentiometer or voltage divider to program the high voltage output. Each unit has an accessible potentiometer allowing for individual calibration after installation. A quasisinewave scillator, internal transformer shielding, and an isolated steel case reduce EMI/RFI radiation to extremely low levels. Suitable for photomultiplier tubes, avalanche photodiodes,

precision EO lenses, piezo devices and other applications requiring precision, low noise, high voltage in a miniature, pc or chassis mount, cost effective package. Also available with the C Series are the CM Series adapter kits. For more details, refer to pages 7 and 8.

Generous quantity discounts are offered.
Typical delivery: stock to one week.
Call or email with your requirements today!

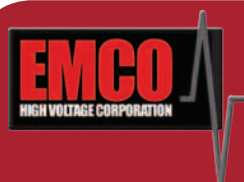

www.emcohighvoltage.com
 e-mail: sales@emcohighvoltage.com
 phone: (209) 267-1630, fax (209) 267-0282
 70 Forest Products Rd., Sutter Creek, CA 95685 USA

MECHANICAL SPECIFICATIONS CA

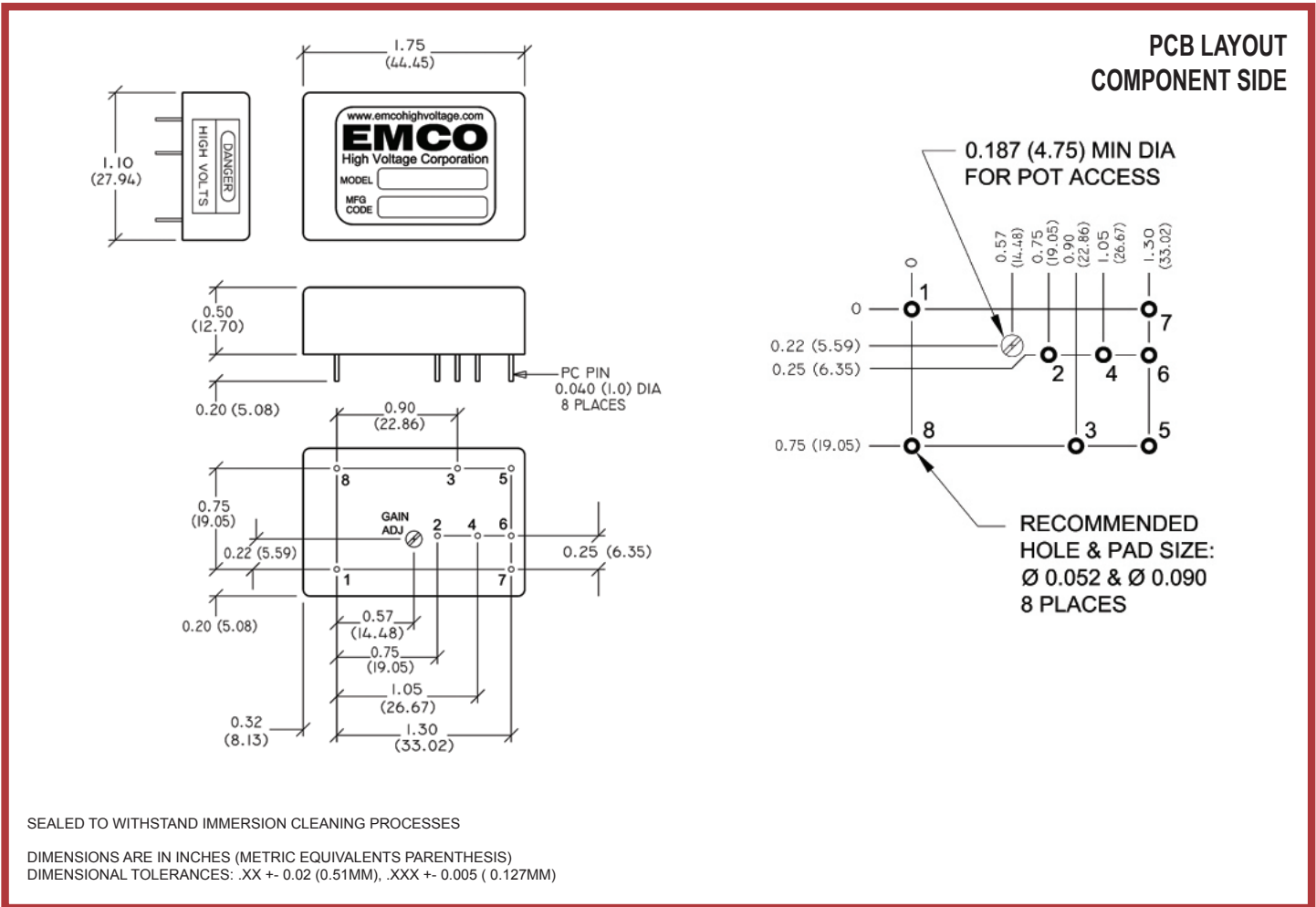

PARAMETER	VALUE
WEIGHT	1.4 OZ. (36.9 GRAMS)
VOLUME	0.96 CUBIC INCHES (15.77 CUBIC CENTIMETERS)
DIMENSIONS	1.75L (44.45L) x 1.10W (27.94W) x 0.50H (12.70H)
CASE MATERIAL	ZINC PLATED STEEL

PIN #	FUNCTION
1	OUTPUT VOLTAGE
2	PROGRAMMING VOLTAGE INPUT
3	GROUND
4	VOLTAGE REFERENCE OUTPUT
5	CASE GROUND ¹⁴
6	INPUT VOLTAGE
7	VOLTAGE MONITOR
8	OUTPUT RETURN



MECHANICAL SPECIFICATIONS CA-T

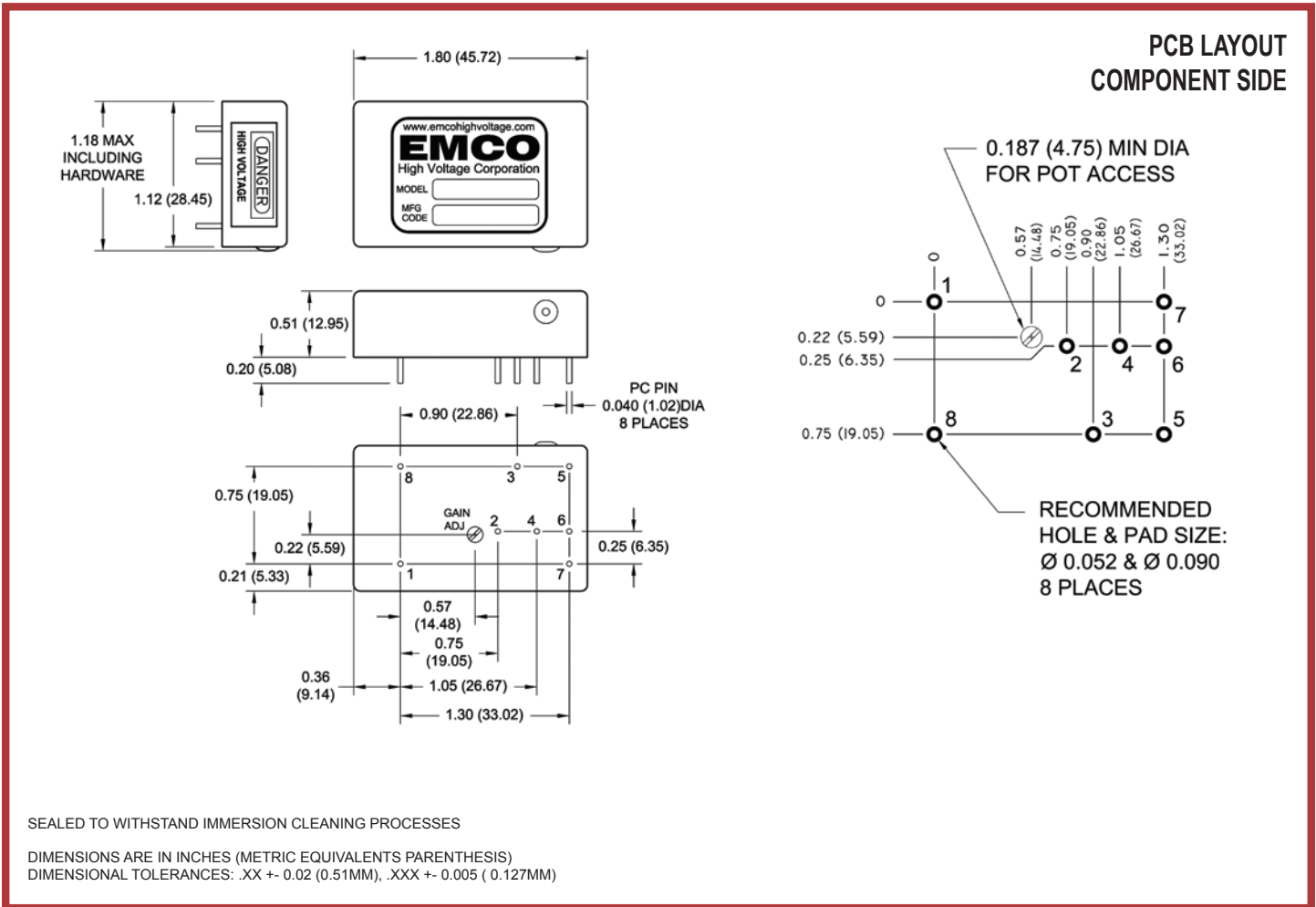

PARAMETER	VALUE
WEIGHT	1.4 OZ. (36.9 GRAMS)
VOLUME	1.03 CUBIC INCHES (16.84 CUBIC CENTIMETERS)
DIMENSIONS	1.80L (45.72L) x 1.12W (28.45W) x 0.51H (12.95H)
CASE MATERIAL	ALUMINUM

PIN #	FUNCTION
1	OUTPUT VOLTAGE
2	PROGRAMMING VOLTAGE INPUT
3	GROUND
4	VOLTAGE REFERENCE OUTPUT
5	CASE GROUND ⁴
6	INPUT VOLTAGE
7	VOLTAGE MONITOR
8	OUTPUT RETURN



www.emcohighvoltage.com
 e-mail: sales@emcohighvoltage.com
 phone: (209) 267-1630, fax (209) 267-0282
 70 Forest Products Rd., Sutter Creek, CA 95685 USA

BLOCK DIAGRAM

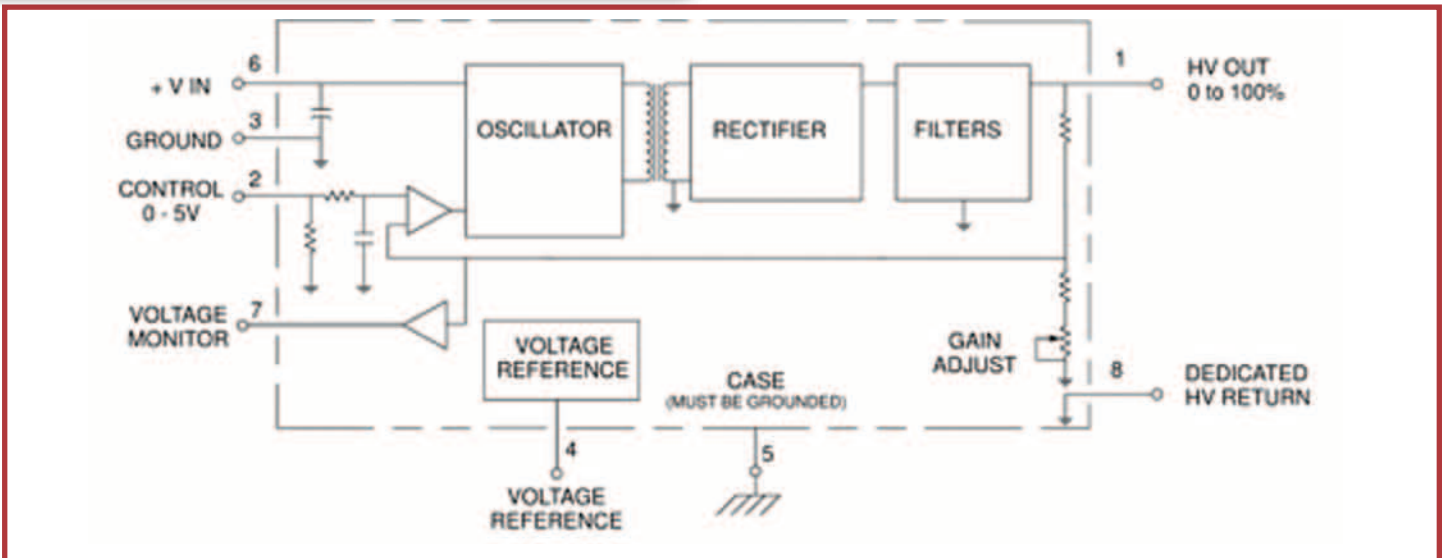

OPTIONS

OPTION	ORDER CODE
POLARITY DESIGNATOR	"P" - For Positive Output
	"N" - For Negative Output
INPUT VOLTAGE	"Blank" - 12 VDC
	"-5" - 5 VDC
TEMPERATURE	"Blank"- Standard Operating Temp -10° to +50°C (Case Temp)
	"T"- Extended Operating Temperature -55° to +70°C (Case Temp)
RoHS	"R" - Version

HOW TO ORDER

PART NUMBER SELECTOR:

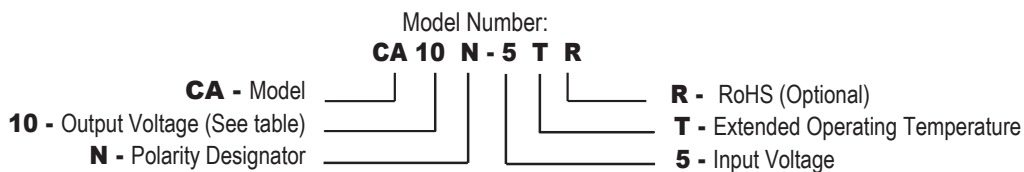

EXAMPLE: **CA10N-5TR** (CA - Model, 10 - Output Voltage, N - Negative, 5 - Input Voltage, T - Extended Operating Temperature, R - RoHS (Optional))

- * Notes:
 1. At Maximum Rated Output Voltage.
 2. Specifications after 1 hour warm-up, full load, at 25°C unless other wise indicated.
 3. Typical Performance
 4. All grounds internally connected, except case. There should not be more than 50 volts potential between the case ground (pin 5) and the circuit ground (pins 3 and 8). Isolated case assists low noise design efforts. Case pin must be connected to ground for proper operation.
 5. On negative output models, voltage monitor output is a buffered representation of the programming voltage.



www.emcohighvoltage.com
 e-mail: sales@emcohighvoltage.com
 phone: (209) 267-1630, fax (209) 267-0282
 70 Forest Products Rd., Sutter Creek, CA 95685 USA

CM1: ALL CA MODELS

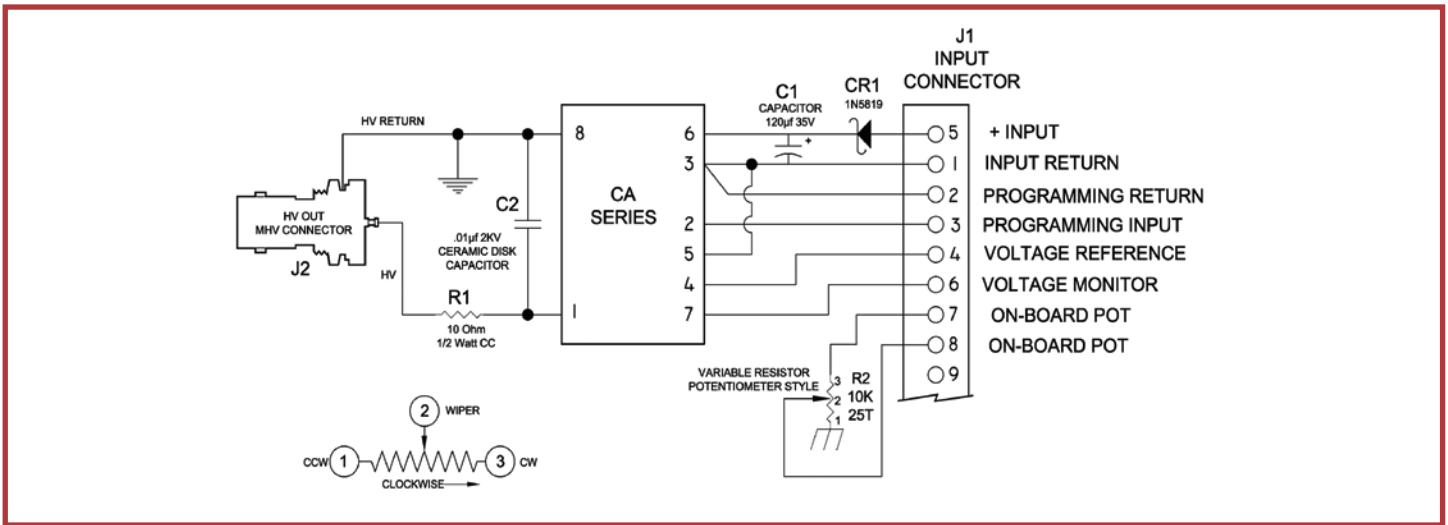
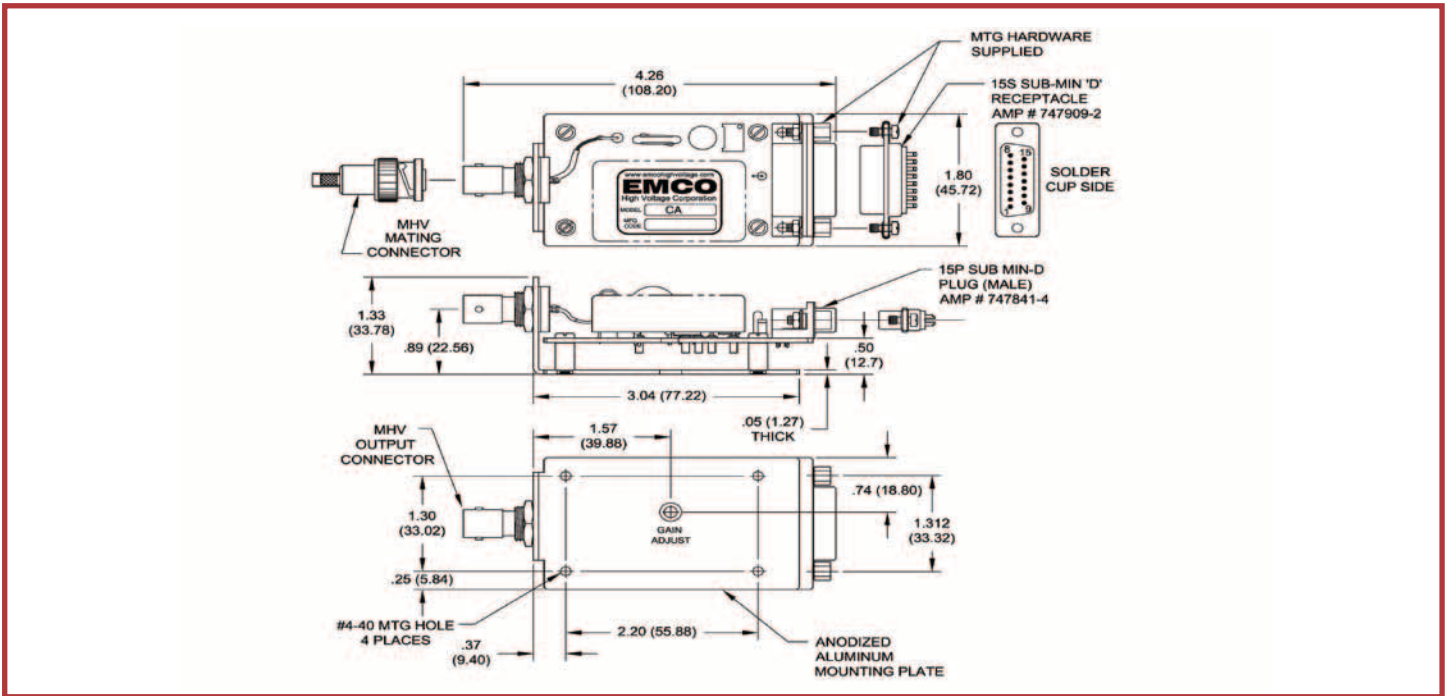

PRODUCT DESCRIPTION

PROGRAMMING OPTIONS / INSTRUCTIONS

These adapters provide convenient proto-typing and evaluation during system development and integration, and allow these modules to be mounted to a chassis instead of designed in to a pc board. Extra filtering on the input and output improves performance. A schottky diode on the input provides reverse polarity protection. Input connector is via a 15P SUB MIN-D plug (mate supplied) and output is via an MHV style coaxial connector (mate supplied).

1. Onboard Potentiometer: connect pins 7 to 4 and 8 to 3, turn potentiometer to adjust high voltage.
2. Remote Potentiometer: connect wiper arm to pin 3, other sides to pins 4 and 2.
3. Remote Analog Signal: apply programming voltage to pin 3, return to pin 2.

ORDERING INFORMATION:

Please note when ordering a CM1 the CA Series is not included and must be ordered separately.



www.emcohighvoltage.com
 e-mail: sales@emcohighvoltage.com
 phone: (209) 267-1630, fax (209) 267-0282
 70 Forest Products Rd., Sutter Creek, CA 95685 USA

CM2: ALL CA MODELS

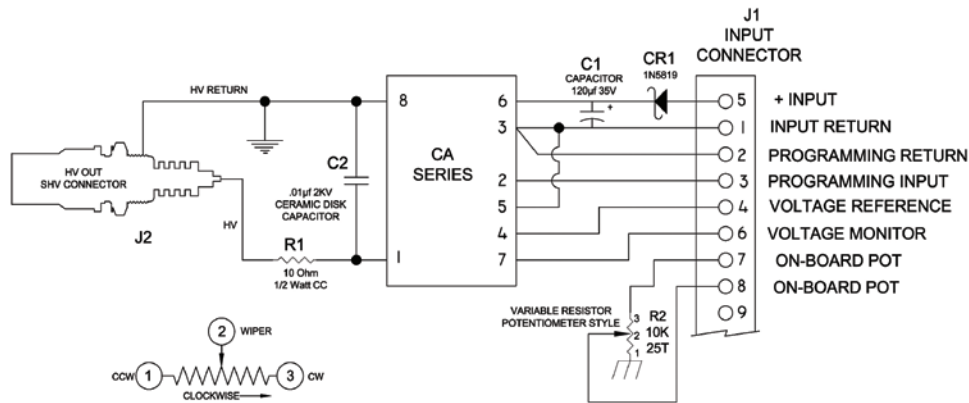
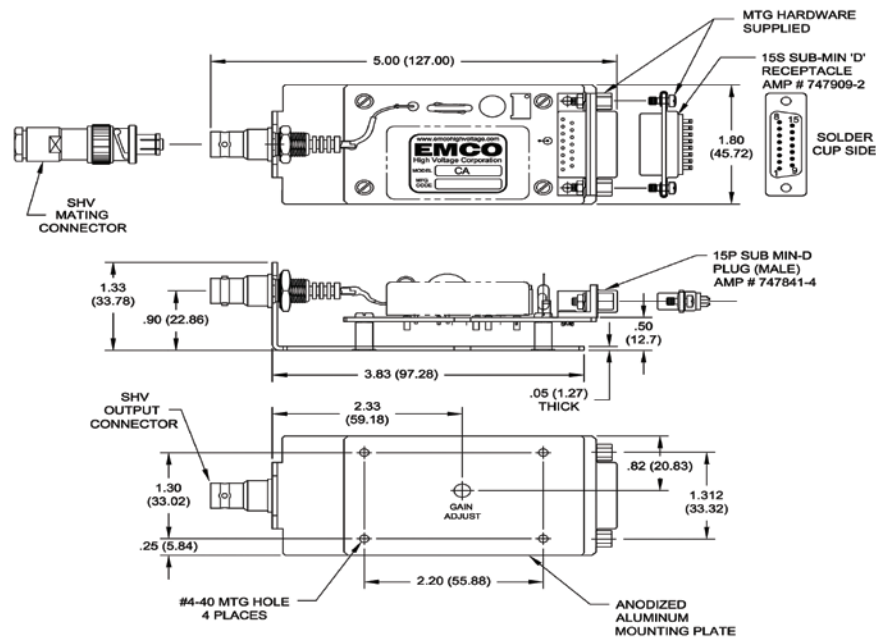

PRODUCT DESCRIPTION

These adapters provide convenient proto-typing and evaluation during system development and integration, and allow these modules to be mounted to a chassis instead of designed in to a pc board. Extra filtering on the input and output improves performance. A schottky diode on the input provides reverse polarity protection. Input connector is via a 15P SUB MIN-D plug (mate supplied) and output is via an SHV style coaxial connector (mate supplied).

ORDERING INFORMATION:

Please note when ordering an CM2 the CA Series is not included and must be ordered separately.

PROGRAMMING OPTIONS / INSTRUCTIONS

1. Onboard Potentiometer: connect pins 7 to 4 and 8 to 3, turn potentiometer to adjust high voltage.
2. Remote Potentiometer: connect wiper arm to pin 3, other sides to pins 4 and 2.
3. Remote Analog Signal: apply programming voltage to pin 3, return to pin 2.

